



Benchmark™ 450

VIEW Benchmark 450 delivers the high performance and reliability required for production process qualification and monitoring.

- High precision single or dual magnification fixed lens optical system
- Advanced image processing for high speed, accuracy and precision
- Choice of powerful metrology software and data analysis tools

	X	Y	Z
Travel (mm)	450	450	200

High Performance Optical Metrology System



Benchmark™ 450

Standard Metrology Software

- VIEW Metrology Software (VMS)

Optional Metrology Software

- Elements® Metrology Software
- Measure-X® Metrology Software

Optional Software Modules

- Area Multi-Focus (AMF)
- Extended Depth of Field Image (EDFI)
- Continuous Image Capture (CIC)
- Advanced Image Processing
- COM and Custom UI
- MeasureFit® Plus
- SmartProfile® GD&T Evaluation Software
- VMS Offline Image Processing Workstations

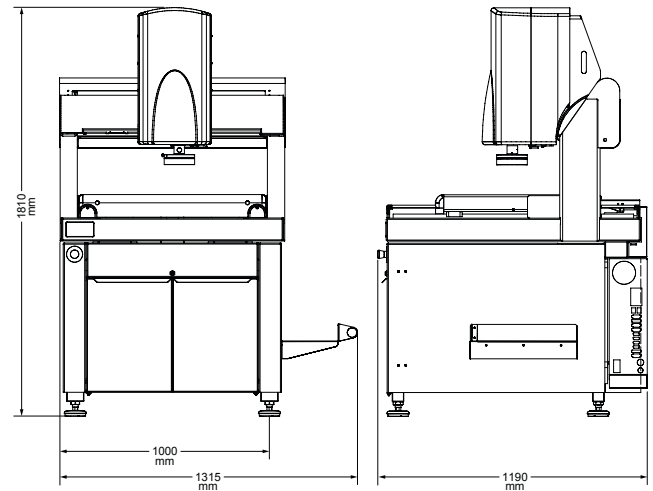

System Weight: 935 kg
Shipping Weight: 1135 kg

	Standard		Optional	
XYZ travel	450 x 450 x 200 mm		450 x 600 x 200 mm	
XYZ scale resolution	0.1 µm (dual Y axis scales)			
Stage drive system	DC Servo Motor, X,Y,Z			
Max recommended load	65 kg			
Imaging optics	Single magnification, fixed lens optics with factory configurable back tube and field interchangeable front lens		Dual magnification, fixed lens optics with field interchangeable front lens	
Back tube (factory installed)	VIEW 1X back tube		VIEW 2X back tube (Available for single magnification optics only. FOV changes when 2X back tube applied.)	
Standard front lens	VIEW 2.5X	FOV 2.78 x 2.07 mm	VIEW 2.5X (DMO)	FOV Low: 2.78 x 2.07 mm FOV High: 0.64 x 0.48 mm
Optional front lenses (field interchangeable)			Lens Option	Single Mag FOV Dual Mag FOV
			VIEW 0.8X	8.34 x 6.23 mm Low: 8.34 x 6.23 mm High: 1.91 x 1.43 mm
			VIEW 1X	6.46 x 4.82 mm Low: 6.46 x 4.82 mm High: 1.59 x 1.19 mm
			VIEW 5X	1.35 x 1.01 mm Low: 1.35 x 1.01 mm High: 0.31 x 0.23 mm
			VIEW 10X	0.69 x 0.52 mm Low: 0.69 x 0.52 mm High: 0.16 x 0.12 mm
			VIEW 25X	0.28 x 0.21 mm Low: 0.28 x 0.21 mm High: 0.06 x 0.05 mm
Metrology camera	2.0 megapixel (1628 x 1236), digital, monochrome metrology camera		Color and other camera configurations are optionally available	
Illumination	Programmable LED illumination system for coaxial through-the-lens surface light, below-the-stage backlight, and multi-color ring light with motorized incidence angle control		Grid autofocus system	
Sensor options			Through-the-lens (TTL) laser Rainbow Probe™ off-axis white light range sensor	
Measurement modes	High Speed Move And Measure (MAM)		Continuous Image Capture (CIC)	
System controller	Intel® processor based Microsoft® Windows® operating system and on-board networking and communication ports			
Controller accessory package	QVI multifunction handheld controller with 3-axis joystick and illumination controls		Single LCD flat panel display, computer keyboard and mouse Dual LCD flat panel displays, computer keyboard and mouse Space saving operator workstation desk with dual monitor mounts	
Power requirements	100-120 VAC or 200-240 VAC, 50/60 Hz, 1 phase, 700 W			
Safe operating environment	15-30 °C			
Rated environment	Temperature 18-22 °C, stable to ±1 °C, max rate of change 1 °C / hour, max vertical gradient of 1 °C / meter; 30-80% humidity; vibration <0.001 g below 15 Hz			
XY area accuracy	E ₂ ; (2.5 + 5L/1000) µm			
Z linear accuracy	E ₁ ; (2.0 + 8L/1000) µm		E ₁ ; (2.0 + 5L/1000) µm (requires Rainbow Probe)	

Accuracy is evaluated with a QVI verification procedure where "L" is measured length in millimeters. Specifications apply within the rated environment. Accuracy specifications are applicable when configured with a 2.5X or higher front objective lens. XY Accuracy applies with an evenly distributed load up to 5 kg in the standard measuring plane. The standard measuring plane is defined as a plane that is within 25 mm of the worktable surface. Depending on load distribution, accuracy at maximum payload may be less than standard. Accuracy specifications do not apply to Continuous Image Capture (CIC) mode.



VIEW, a division of Quality Vision International

1711 W 17th Street • Tempe, Arizona 85281-6229 • USA

Phone: (480) 295-3150 • (800) SOS-VIEW • Fax: (480) 889-9059

sales@viewmm.com • viewmm-service@qvii.com

www.viewmm.com