

**Benchmark™ 250**

**VIEW Benchmark 250** delivers high performance and reliability in a compact, benchtop package.

Advanced optics, illumination, image processing and available EDFI imaging make VIEW Benchmark a world-class metrology system.

VIEW metrology software (VMS™) offers an advanced programming language for complex, high throughput metrology with a customized production floor user interface.

- Single or dual magnification fixed lens optical system
- Advanced image processing for high speed, accuracy and precision
- Powerful metrology software and data analysis tools

	X	Y	Z
<b>Travel (mm)</b>	300	150	200

## High Speed Optical Metrology System



## Standard Metrology Software

- VIEW Metrology Software (VMS)

## Optional Metrology Software

- Elements® Metrology Software
- Measure-X® Metrology Software

## Optional Software Modules

- Area Multi-Focus (AMF)
- Extended Depth of Field Image (EDFI)
- Continuous Image Capture (CIC)
- Advanced Image Processing
- COM and Custom UI
- MeasureFit® Plus
- SmartProfile® GD&T Evaluation Software
- VMS Offline Image Processing Workstation

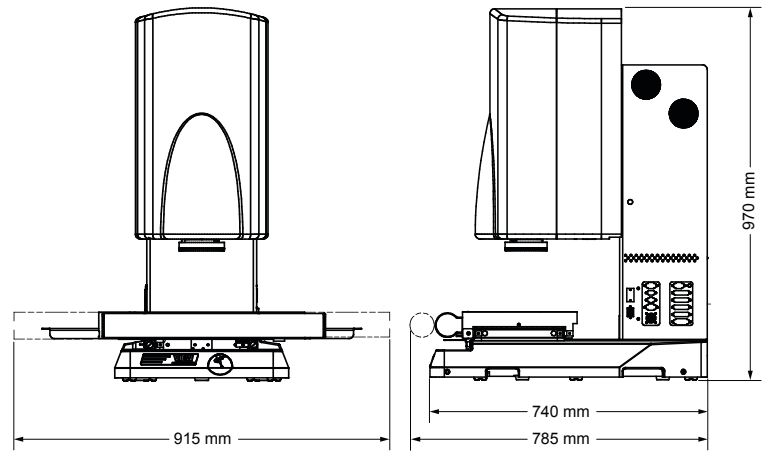

System Weight: 145 kg  
Shipping Weight: 315 kg

	Standard		Optional		
<b>XYZ travel</b>	300 x 150 x 200 mm				
<b>XYZ scale resolution</b>	0.1 µm		0.05 µm (dual scales for X axis)		
<b>Stage drive system</b>	DC Servo Motor, X,Y,Z				
<b>Max recommended load</b>	25 kg				
<b>Imaging optics</b>	Single magnification, fixed lens optics with factory configurable back tube and field interchangeable front lens		Dual magnification, fixed lens optics with field interchangeable front lens		
<b>Back tube (factory installed)</b>	VIEW 1X back tube		VIEW 2X back tube (Available for single magnification optics only. FOV changes when 2X back tube applied.)		
<b>Standard front lens</b>	VIEW 2.5X	FOV 2.78 x 2.07 mm	VIEW 2.5X (DMO)	FOV Low: 2.78 x 2.07 mm FOV High: 0.64 x 0.48 mm	
<b>Optional front lenses (field interchangeable)</b>			Lens Option	Single Mag FOV	Dual Mag FOV
			VIEW 0.8X	8.34 x 6.23 mm	Low: 8.34 x 6.23 mm High: 1.91 x 1.43 mm
			VIEW 1X	6.46 x 4.82 mm	Low: 6.46 x 4.82 mm High: 1.59 x 1.19 mm
			VIEW 5X	1.35 x 1.01 mm	Low: 1.35 x 1.01 mm High: 0.31 x 0.23 mm
			VIEW 10X	0.69 x 0.52 mm	Low: 0.69 x 0.52 mm High: 0.16 x 0.12 mm
			VIEW 25X	0.28 x 0.21 mm	Low: 0.28 x 0.21 mm High: 0.06 x 0.05 mm
<b>Metrology camera</b>	2.0 megapixel (1628 x 1236), digital, monochrome metrology camera		Color and other camera configurations are optionally available		
<b>Illumination</b>	Programmable LED illumination system for coaxial through-the-lens surface light, below-the-stage backlight, and multi-color ring light with motorized incidence angle control		Grid autofocus system		
<b>Sensor options</b>			Through-the-lens (TTL) laser Rainbow Probe™ off-axis white light range sensor		
<b>Measurement modes</b>	High Speed Move And Measure (MAM)		Continuous Image Capture (CIC)		
<b>System controller</b>	Intel® processor based Microsoft® Windows® operating system and on-board networking and communication ports				
<b>Controller accessory package</b>	QVI multifunction handheld controller with 3 axis joystick and illumination controls		Single LCD flat panel display, computer keyboard and mouse Dual LCD flat panel displays, computer keyboard and mouse Space saving operator workstation desk with dual monitor mounts		
<b>Power requirements</b>	100-120 VAC or 200-240 VAC, 50/60 Hz, 1 phase, 700 W				
<b>Safe operating environment</b>	15-30 °C				
<b>Rated environment</b>	Temperature 18-22 °C, stable to ±1 °C, max rate of change 1 °C / hour, max vertical gradient of 1 °C / meter; 30-80% humidity; vibration <0.001 g below 15 Hz				
<b>XY area accuracy</b>	E <sub>z</sub> : (1.8 + 6L/1000) µm		E <sub>z</sub> : (1.0 + 6L/1000) µm (requires 0.05 µm dual scale option)		
<b>Z linear accuracy</b>	E <sub>z</sub> : (2.0 + 5L/1000) µm		E <sub>z</sub> : (1.4 + 5L/1000) µm (requires Rainbow Probe)		

Accuracy is evaluated with a QVI verification procedure where "L" is measured length in millimeters. Specifications apply within the rated environment. Accuracy specifications are applicable when configured with a 2.5X or higher front objective lens. XY Accuracy applies with an evenly distributed load up to 5 kg in the standard measuring plane. The standard measuring plane is defined as a plane that is within 25 mm of the worktable surface. Depending on load distribution, accuracy at maximum payload may be less than standard. Accuracy specifications do not apply to Continuous Image Capture (CIC) mode.



**VIEW, a division of Quality Vision International**

1711 W 17th Street • Tempe, Arizona 85281-6229 • USA

Phone: (480) 295-3150 • (800) SOS-VIEW • Fax: (480) 889-9059

sales@viewmm.com • viewmm-service@qvii.com

www.viewmm.com